

CONCEPT FOR MODELLING A CONTROL SYSTEM USING THE CHARACTERISTICS-PROPERTIES MODELLING (CPM)

A. Crostack, M. Heidingsfeld, H. Binz, O. Sawodny and D. Roth

Keywords: characteristics-properties modelling (CPM), control systems, mechatronic systems

1. Introduction

These days, customers demand low costs and individualised products. This situation has resulted in shortened product life cycles and development processes. Regarding these challenges, the development of products necessitates the co-operation of mechanical and electrical engineering as well as information technology. Mechatronic systems consist of basic systems, sensors, actuators and information processing. Basic systems consist of a mechanical, electro-mechanical, hydraulic, or pneumatic structure, or combinations of these. Sensors determine the state of basic systems based on the measurement of selected physical quantities. Using these, the information processing determines necessary inputs to the basic system. These inputs are realised by the actuators [VDI 2004].

As a result of the development of mechatronic systems, co-operation and communication between involved domains have to be supported, so that they can be developed effectively and efficiently. Each of the domains has its own methods, tools and experiences as well as terms. Thus, for enabling the development of mechatronic systems “a common accompanying language among the developers” is necessary [VDI 2004]. According to Sendler [2012], the main problems are insufficient communication, co-operation and synchronisation of all persons involved. Although the tools used to support development processes result in a qualitative improvement of products and development processes, there are still challenges achieving a continuous data structure of the product models. There is also a lack of suitable approaches to link existing models and to create data models with an appropriate level of detail in development and manufacturing. Both science and industry develop new methods and tools for improving the current status quo concerning the problems mentioned. Future generations of tools have to enable designers to communicate and co-operate in an efficient way and enable developers to get an overview of subsequent or parallel steps of the development process [Sendler 2012].

Therefore error-free exchange of data has to take place without influencing the developer’s individual development environment [Stiegler et al. 2012]. One example of this can be found in [Hagelshuer 2013] with the development of an interface between PTC Windchill and Eplan Electric P8, to exchange data using bills of materials. In this example, different models of the product, each representing a specific view of the product, are connected.

However, according to Stiegler et al. [2012], the use of one central system model leads to a simplification of co-operation and data exchange between all domains involved, because of the clearly defined communication paths and the opportunity to reuse knowledge. Zingel et al. [2012] summarises that “there is no generally accepted modelling language for engineers and managers of all disciplines due to the excessive level of complexity in application and/or representation. A consistent model-based system documentation and representation technique including easily comprehensible

traceability, especially between objectives and system architecture, still does not exist” [Zingel et al. 2012].

2. Problem statement and goals

Based on the aforementioned challenges, further research concerning system models is necessary. There are two different ways of fulfilling the demands. Firstly, several different system models, each representing a specific view of a product, can be used, resulting in increased effort to synchronise these models. This approach is used for example in the partial models of Frank [2006]. Secondly, one central system model, as also proposed by Stiegler [2013], can be used for capturing all the necessary information relating to a product. The research representing this kind of product modelling is presented in this contribution. In doing so, the question of how to model complex mechatronic systems, the dependencies between different departments of product development (e. g. of the mechanical design and resulting effects on the development of controller structures) from the designer’s point of view have to be examined.

The Characteristics-Properties Modelling (CPM) by Weber and Wener [2000] represents an approach of design methodology which, due to its generic character, should be able to model the above-mentioned aspects within a central system model. However, literature shows that there are still some open research questions to answer before CPM can be used for such a model. According to Weber, the approach should be able to model mechanical as well as mechatronic products, but the latter have still not been examined [Weber 2012].

Control systems also contain the elements of mechatronic systems (sensors, actuators, mechanical structure and information processing). The main difference between mechatronics and control systems is their focus. The former focus on interdisciplinary work whereas control systems focus on system theory regardless of the specific domain, e.g. they could be completely mechanical [Paetzold and Schweiger 2002].

For realising the modelling of mechatronic systems using CPM and by considering the differences of mechatronic systems and control systems, the goal of this contribution is to show that control systems can be modelled using CPM and thus its applicability. This modelling of the elements of control systems is a preliminary task for modelling mechatronic systems, thus the central research questions of this contribution can be stated as follows:

Can a closed-loop control system and its component parts be modelled using CPM?

Based on the research question, a hypothesis can be formulated as follows:

Control systems and their component parts can be modelled using CPM.

For the verification of the hypothesis, literature dealing with CPM and different approaches to model mechatronic systems is analysed. To improve the current situation, an approach to model control systems using CPM is elaborated (see Section 4). Following this, the developed approach is implemented by assessing the approach for modelling the control system of a hydraulic cylinder (see Section 5). The contribution concludes with a critical discussion (see Section 6) and provides an outlook for further research (see Section 7).

3. State of the art

First of all, the CPM and – based upon this – the Property-Driven Development (PDD) to model the development process are presented. Then similar approaches to CPM are briefly discussed.

3.1 Characteristics-Properties Modelling (CPM)

Weber and Wener [2000] presented a new approach for modelling products (CPM) and their associated development process (PDD). One motivation for Weber was the lack of activity by the design society in the definition of product models focussing on digital product models [Weber and Wener 2000]. According to Weber, not only should another approach be developed but existing approaches should indeed be combined [Weber 2012]. CPM focusses on modelling products by using their characteristics (C_i) and properties. The characteristics define a product itself and can be directly determined by the designer. The properties describe the product’s behaviour and can only be

influenced by its characteristics. The properties are further subdivided into required properties (RP_i) and properties representing the actual state (P_i).

There are two ways of connecting properties and characteristics. Firstly (see Figure 1, left-hand side), there are steps of analysis in which the actual properties of a product are determined by characteristics using different relations (R_i) (e. g. experience, formulas, FE simulations, experiments). Secondly (see Figure 1, centre), the characteristics of a product have to be determined. These steps of synthesis represent the main activity in product development. For the synthesis there is another set of relations (R_i^{-1}). These are for example association, experience or catalogues. Both determination of characteristics and properties has to be carried out considering several external conditions (EC_i) as well as modelling conditions (MC_i) [Weber and Wener 2000]. An example of the latter is a linearised formula which can suitably be used only in the direct environment of the set point. An example for an external condition (EC) is the restriction of a maximum allowed width of a product, because otherwise it cannot be transported in a given container. Some of the product's numerous properties are less important for customers and therefore do not have to be considered by developers. Nevertheless, some of these seemingly unimportant properties have to be considered because they constitute disturbances such as loss of power [Weber and Wener 2000].

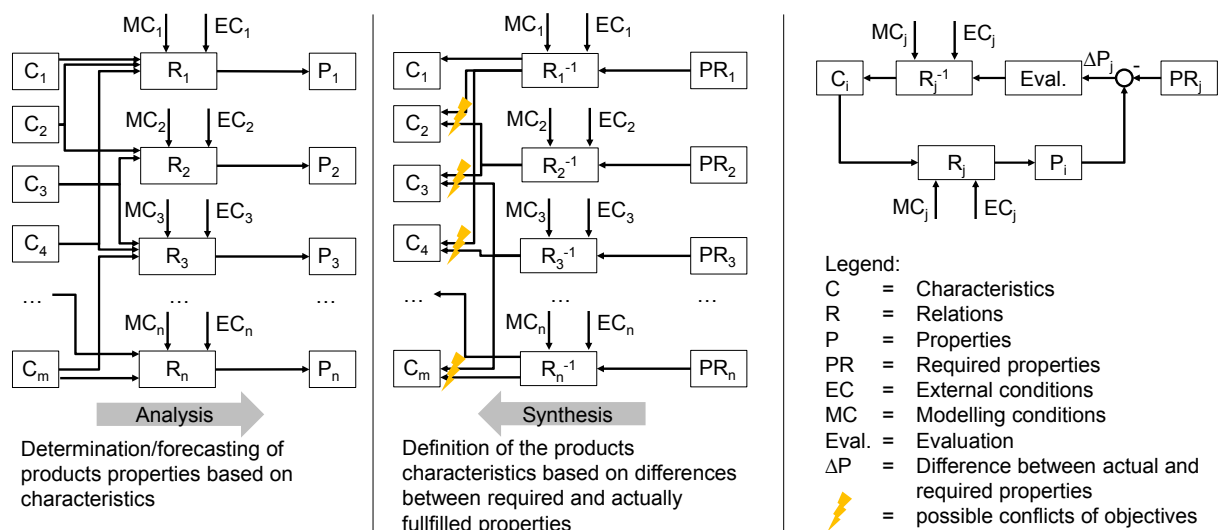

Figure 1. Basic models of analysis and synthesis within the CPM in accordance with Vajna et al. [2009] and basic control loop of PDD according to [Weber 2005]

Weber's approach can also be used for modelling product development processes (PDD). Here, processes can be seen as continuously switching between analysis and synthesis and can therefore be modelled like a control loop (see Figure 1, right-hand side). In each step more characteristics (synthesis step) or properties (analysis step) can be determined or already known ones can be determined more precisely. The control loop comprises the four major steps: Determination of characteristics based on required properties or the difference between required and actual properties, definition of actual properties, determination of the differences and the decision whether the cycle is run through again [Weber 2005]. There are some extensions to CPM (e. g. the Change Impact Risk Analysis, CIRA) which are not presented here. An overview of them is given in [Weber 2012].

3.2 Comparison of the CPM and similar approaches

Although there are some different approaches (e. g. CPM, Axiomatic design) to model products, not all of them are equally suited. Therefore, in the following a comparison of the approaches is presented. The requirements used for this selection process are derived from the actual research project of the IKTD within the research unit 918 ("hybrid intelligent design elements). Goal of the project is the development of a knowledge base, which helps the different development departments synchronizing their knowledge based on a single product model.

Modelling products from a designer's point of view leads to several requirements that have to be fulfilled. Firstly, designers have to recognise and know which dependencies and contradictions exist. Here, it is useful to divide the attributes into characteristics and properties, so that the direct influence of designers of one department on another one can be modelled and predicted. Therefore, it becomes necessary to model the relations between the characteristics and properties as well. The modelling of design guidelines, which show influences of other domains (e. g. manufacturing), has to be performed so that any resulting changes or constraints are considered. Literature shows that there are several models (e. g. FE model) used within the development process. Their boundary conditions have to be additionally considered. Especially in control engineering, the effects of disturbance have to be recognised. The distinction between analysis and synthesis is not essential if products only are modelled. However, if the development process and its different iterations are to be modelled, this distinction becomes important. Since the presented research focusses on product modelling, the approaches have to support the embodiment phase of the development process. Although, it can be stated that focusing on the embodiment phase exclusively is not sufficient to support the whole development process, it is the starting point of this research. However, Kaiser [2014] also explains the need of further research regarding an increasing coordination of the development departments within the embodiment design by the modelling of products. Due to the advantages of a central system model described in the introduction, this kind of system has to be developed. Table 1 summarises the results of this comparison.

Table 1. Comparison of CPM and similar approaches

Criteria Modeling of ...	Characteristics- Properties- Modeling (CPM) of Weber	Axiomatic Design of Suh	Partial Models of Frank	Property driven development following Wäldele	Property driven development following Krehmer and Luft	Modelled- Based-Systems- Engineering (MBSE)	Function- Behaviour- Structure (FBS) following Gero
... characteristics	●	◐	◐	●	●	◐	●
... properties	●	◐	◐	●	●	◐	●
... relations connecting them	●	◐	◐	◐	●	◐	◐
... design guidelines (e.g. DfX) [EC]	●	◐	◐	◐	◐	◐	◐
... uncertainties of Models [MC]	●	◐	◐	◐	◐	◐	●
... disturbances [EC]	●	◐	●	◐	◐	◐	●
... distinction between Synthesis and Analysis	●	◐	◐	◐	●	◐	●
... mechatronic systems	◐	●	◐	◐	◐	◐	●
Support the embodiment phase	◐	◐	◐	◐	◐	◐	◐
Result in one central product model	●	●	◐	●	●	◐	●

● = complete fulfillment ◐ = partial fulfillment
◐ = requirement is not considered or only focussed upon secondarily

The main problem of CPM are the lack of a procedure for how to manage the complexity of models and that, there are no commercial software tools using CPM in the aforementioned form.

In Axiomatic Design by Suh [1998], Functional Requirements (FR) are defined as “a minimum set of independent requirements that completely characterises the functional need of the product”. Hence, only characteristics and properties as well as their connections concerning the product's functions are considered. Analysis and synthesis are not explicitly mentioned but appear as a process called “zigzagging” [Suh 1998]. Differences from CPM are the more mathematical approach (linearity, matrix driven approach) and the resulting restrictions. Limitation of the functional needs of products, claim of minimised number of independent FR and a less detailed view of external conditions (e. g.

disturbances, design guidelines) and modelling conditions (e. g. uncertainties of models) are further differences. A detailed discussion of the differences can be found in [Weber 2005].

The partial models first presented by Frank [2006] use several models which have to be synchronised instead of a single model. In this approach, the partial models focus on the conceptual phase of product development, resulting in several restrictions. The approaches presented in [Frank 2006], [Rieke et al. 2012] and [Kaiser 2013] show no distinction between characteristics and properties, although these elements and their relations in the conceptual phase are captured. The work of Rieke et al. uses the partial model “behaviour” as a domain-spanning model and derives domain-specific models from it to ensure their synchronisation. His work is located in the transition area between the conceptual and the embodiment phase. A direct modelling of design guidelines (EC) or the modelling conditions (MC) is not explicitly considered, but these elements are considered implicitly in the different partial models. No direct distinction is made between analysis and synthesis.

Wäldele’s approach [2012] includes the modelling of external conditions or modelling conditions like in the CPM, although some of the external conditions appear as process properties. Connections between the dependent properties (represent the properties in CPM) and the independent properties (represent the characteristics in CPM) are only qualitatively modelled. Furthermore, no distinction is made between analysis and synthesis. The developed approach was not used for modelling mechatronic systems or control systems [Wäldele 2012].

Both Krehmer [2012] and, based on this, Luft [Luft and Wartzack 2013], [Luft et al. 2013] focus on the implementation of the basics of CPM in development processes. In doing so, Luft evaluates the process using different examples. Although the basic elements of CPM are used (characteristics and properties), the modelling of external conditions (EC) and modelling conditions (MC) is still not provided. Additionally, the question of how to manage the complexity of such models is not further examined. The approach is only used to model common mechanical systems.

The contributions of Zingel et al. [2012] and Stiegler et al. [2012] represent approaches from the research field of model-based systems engineering (MBSE). Zingel describes in detail the combination of the contact and channel-approach (C&C²-A) with the system modelling language (SysML) and the resulting advantages. Stiegler et al. presents the modelling of an automatic gearbox using SysML at AVL List GmbH. One type of information which could not be modelled using SysML are time-dependent functions. Both contributions focus on the modelling of the active structure, thus they focus on the conceptual phase. The detailed modelling of products by characteristics and resulting properties is not described, although these elements are collected for the conceptual phase. Zingel focuses on the conceptual phase, although there are connections to the embodiment design. A clear distinction between analysis and synthesis is discussed but not shown in the models. Furthermore, Stiegler states that the currently available support for modelling using SysML still needs to be improved by appropriate software tools [Stiegler et al. 2012]. Gausemeier states that the development of SysML is driven by software engineering; hence mechatronic systems cannot be modelled in a user-friendly way. This leads to aversions especially in mechanical engineering [Gausemeier et al. 2012].

The Function-Behaviour-Structure framework of Gero and Kannengiesser [2004] shows several communalities with CPM. However, the connections between the elements (relations in CPM) are not described in detail. Additionally, neither external nor modelling conditions are explicitly considered [Gero and Kannengiesser 2004].

4. Modelling of a two-degree-of-freedom controller structure using CPM

Keeping in mind the central question of this contribution of how to model control systems using CPM, the elements of control systems which have to be considered have to be determined. Furthermore, the depiction’s level of detail has to be set. Then the connections between the elements of control systems and of CPM (characteristics, relations with external conditions and modelling conditions as well as properties) have to be identified. Finally, the depiction of a generic control system is presented.

The aim of control systems is to let the control variable follow the reference variable, keeping the control error at zero despite the presence of external disturbances and modelling errors. The basic elements of control systems are, comparable to mechatronic systems, sensors, actuators, controllers and the plant. The term ‘plant’ means the process or system to be controlled, e.g. the mechanical

structure of a mechatronic system. The controller determines the actuating variable based on the measured variables and an external reference variable. State-of-the-art control engineering offers a wide range of different types of controllers arranged in various possible control structures. With the objective of modelling a typical and generic control system, a so-called two-degree-of-freedom control structure will be analysed. This control structure consists of two independent controllers that both contribute to the control action. The feedforward controller reacts to changes in the reference variable in order to make the control variable follow the desired value. Since the feedforward controller controls the plant directly without utilising any measured signals, it is also called an open-loop controller. The feedback controller, on the other hand, uses the control error, which is the difference between the reference and the (measured or estimated) control variable, and thereby closes the control loop. It is used to ensure stability and disturbance rejection [Dorf and Bishop 2011].

Both feedforward (open-loop) and feedback (closed-loop) controller are summarised and called information processing in [VDI 2004]. The specific type of controller (e.g. PID) has no influence on the presented approach and has to be chosen adequately by the control engineer.

The overall behaviour of the control system is affected by the complex interplay of its elements regarding their particular behaviour. Here, the term behaviour is used to describe the dynamic relation between the input and output of an element. The behaviour of the plant and the behaviour of the feedback as well as feedforward controller obviously have a strong influence on the behaviour of the control system (equivalent to the behaviour of the whole system examined) and thus must always be taken into account. In general, the behaviour of sensors and actuators also influences the closed-loop control system. In the case of sensors, the dynamics of the underlying electrical circuits are typically fast compared to the dynamics of the plant such that their influence can usually be neglected. However, in many cases the control variable cannot be measured directly and the measurement is corrupted by noise. Therefore the behaviour of the sensors is considered explicitly. In contrast, the behaviour of the actuators is not considered explicitly here, as they can always be interpreted as part of the plant.

Next, the level of detail will be determined. In general, the behaviour of each element of the control system is the result of the definition of its characteristics. For example, the behaviour of a hydraulic cylinder is among others influenced by its mass and the geometry of the cylinder and piston [Weickgenannt 2013]. Those characteristics can also be modelled using CPM. This contribution focuses on the control system and therefore it is assumed that the behaviour of the sensors and the plant is given, because they are purchased parts for example, and thus cannot be influenced by the control engineer. Additionally, an actuator of the examined system is modelled.

In accordance to Weber and Wener [2000] the interaction of feedback and feedforward controller, plant and sensors corresponds to analytical relations of CPM. The selection and design of suitable controllers are synthesis steps. In contrast to most other applications of CPM, properties of control systems are dynamic. Figure 2 illustrates the general case of a control system in a two-degree-of-freedom control structure using CPM. On the left side are the characteristics that determine the behaviour of the feedforward and feedback controller, the plant and the sensor. In the central part of Figure 2 the analytical relations are shown. The right-hand side of Figure 2 shows the properties. Within the analytical relations the control error $e(t)$, as a property, is determined by the external reference variable $y_d(t)$ and the measured variable $y_m(t)$. The latter will be generated by the sensor and is influenced by the control variable $y(t)$ the behaviour of the sensor and the noise $w(t)$. The control variable $y(t)$ is then determined by the actuating variable $u(t)$, the behaviour of the plant (including the behaviour of the actuators), as well as an external disturbance $z(t)$ which cannot be influenced by the designer and is therefore considered as an external condition. The behaviour of the feedback and feedforward controller together with the control error and the reference variable define the actuating variable $u(t)$. Following the principles of CPM, every relation defines exactly one property. The actuating variable $u(t)$, the control variable $y(t)$ and the control error $e(t)$ are important properties for evaluating closed-loop control systems. The step of synthesis is shown in the upper part of Figure 2 for the sake of completeness and clarity. This step includes the design of both controllers, which includes the selection of suitable types of controllers as well as the quantitative determination of their parameters. This will not be further examined in this contribution.

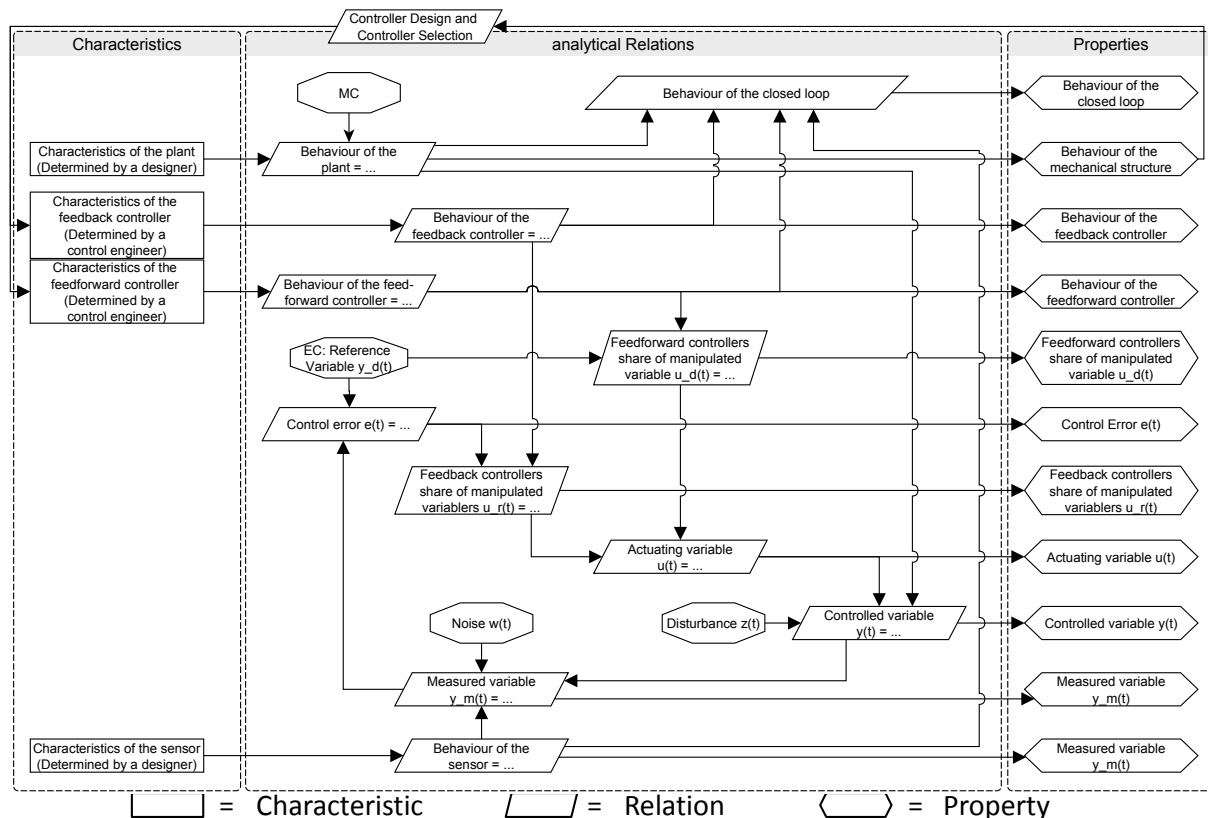

Figure 2. Depiction of a general two-degree-of-freedom controller structure using the CPM

5. Application scenario: Positioning control of a hydraulic cylinder

The previously described concept will now be applied to the example of positioning control of a hydraulic cylinder according to [Weickgenannt 2013]. This positioning control is part of the control system of the Stuttgart SmartShell. The SmartShell is a prototype for a lightweight civil structure that can actively adapt to external loadings. For this adaption hydraulic cylinders are used.

The aim of the control system is to let the piston follow the desired position keeping the control error at zero despite the presence of external disturbances (e.g. forces) and modelling errors. In this case, the control error is the difference between the piston's target and actual position. Hence, the control variable is the piston's position. Since it can be measured directly at high sampling frequencies using a high resolution digital position sensor, the behaviour of the sensor is not considered here. The actuating variable is the valve position controlling the oil flow to the hydraulic cylinder. Since the magnetic actuation of the valve is fast compared to the dynamics of the hydraulic system, the behaviour of the valve is not considered either. In general, a hydraulic cylinder shows a non-linear response from the valve position (actuating variable) to the piston position (control variable). However, under certain assumptions (these are stored as modelling conditions in the CPM) the dynamic behaviour of the cylinder can be simplified to pure integrating behaviour. The behaviour of the feedforward controller is chosen to be reciprocal to the behaviour of the mechanical structure and is hence differentiating, so that the behavioural of the open-loop control system will be equal to one and the control variable follows reference variable immediately. The feedback controller is chosen to be simply proportional (K_r). Figure 3 shows CPM of the hydraulic cylinder's position control system based on Figure 2. By identifying the external reference input, the behaviour of the whole system can be determined quantitatively.

After presenting the positioning control of the hydraulic cylinder, the complex dependencies between mechanical and control engineering and their models shall be described based on one product model. In Figure 4, the behaviour of the hydraulic cylinder and its influencing characteristics are examined in accordance to [Weickgenannt 2013]. The dynamic behaviour of the cylinder is determined by several characteristics and resulting properties. These are the area in each cylinder chamber, the supply and

ambient pressure and the behaviour of the valve. The former can be determined by the diameters of the cylinder and the hydraulic piston, while the pressures are either given or determined by designers.

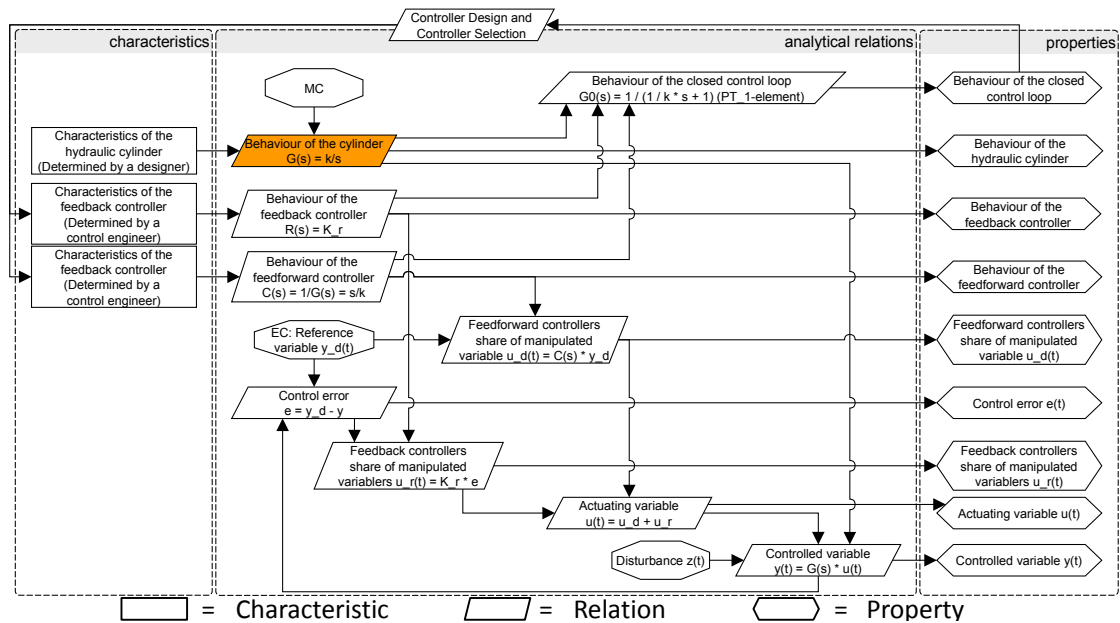

Figure 3. CPM of the closed-loop positioning control of a hydraulic cylinder

The behaviour of the valve and its occurring pressure drop are also results from its characteristics defined by mechanical engineers and can also be modelled in a more exact way by CPM.

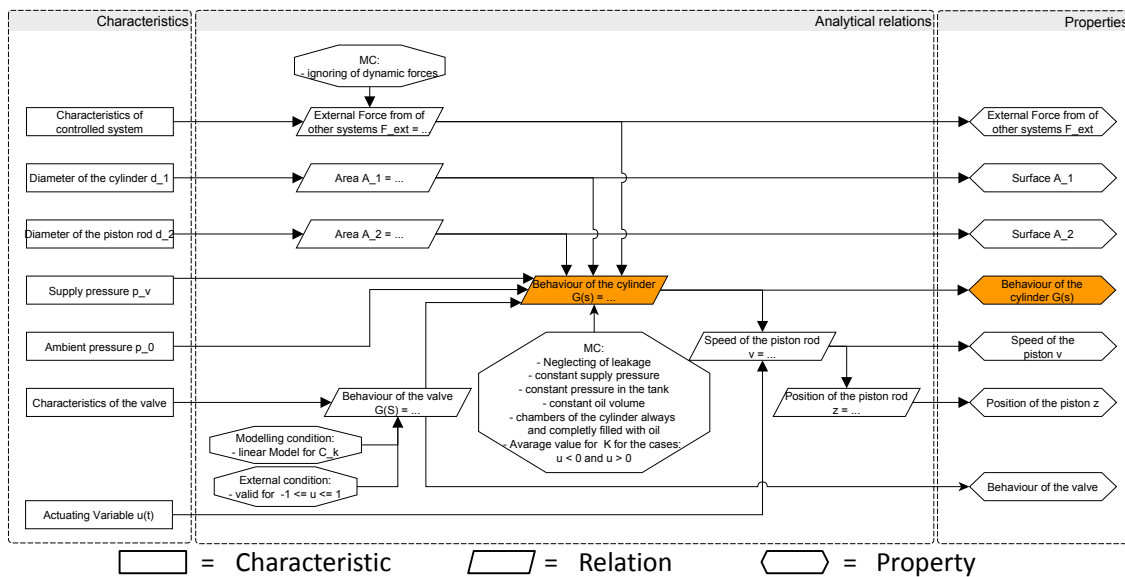

Figure 4. Detailed model of the hydraulic cylinder according to [Weickgenannt 2013]

Here, it is assumed that the external forces result, for example, from the weight of the controlled system, thus the weight can also be determined by a designer. The presented model is based on several simplifications modelled according to [Weickgenannt 2013] as external and modelling conditions. For example, it is assumed that there is no leakage in the system and a constant supply pressure. Both figures (3 and 4) show that the dependencies between mechanical and control engineering can be modelled using CPM. The resulting behaviour of the hydraulic cylinder in Figure 4 corresponds with the behaviour mentioned in Figure 3. Due to reasons of space, the models are not presented as one huge model.

6. Discussion of the results

In this section, the presented results are critically discussed. In addition to this, some implications are presented in order to define further research fields. First of all, it has to be checked whether the research question has been answered. Although the results show that control systems can be modelled using CPM, an unambiguous answer is not possible due to the multitude of possible control systems and the limited number of examples. As a result of this, more different control systems have to be modelled so that the hypothesis can be confirmed for certain. This also has been tested within a student research project by Rheintaler [2013]. The modelling of cascading control systems has also been investigated, but due to lack of space it is not presented here. Difficulties arise in the clear assignment and distinction of the constraints to external and modelling conditions. A detailed examination of the dependencies between mechanical and control engineering has to be carried out so that the complete network of dependencies between them becomes comprehensible. Additionally, there are more interesting dependencies between departments involved at the development of mechatronic products (e. g. software development, simulation and testing departments). For a generic product model all dependencies between the departments have to be captured and modelled too. Although a less complex example was used, it is shown that the developed model rapidly becomes very complex. Furthermore, the procedure to model both mechanical and mechatronic systems by CPM has to be carried out.

7. Conclusion and outlook

This contribution presents a concept for modelling control systems using CPM. In addition to the presented basics of CPM, several similar approaches are discussed. Based on a brief introduction to the structure of mechatronic systems and control engineering, this leads to a first generic model of a two-degree-of-freedom control structure using CPM. Using this, a general model of closed-loop positioning control of a hydraulic cylinder is modelled. Furthermore, in order to show the dependencies between mechanical and control engineering, the characteristics determining the dynamic behaviour of the cylinder are presented. Using the concept, an evaluation and advancement of the concept will be performed in the DFG research unit 981. However, further research which focuses on modelling the dependencies between further departments (e. g. dependencies between software and hardware development) has to be carried out. Then, mechatronic systems and their component parts can be modelled using CPM. It is assumed that by developing a software tool, the effort to model such systems can be significantly reduced. The resulting complex networks leads to another necessary point for research: How can the complexity of the actual needs of the user being reduced? Therefore the approach has to be extended to include a selectable change of detail, for example.

Acknowledgement

The authors would like to thank the Deutsche Forschungsgemeinschaft (DFG) for its support in the research unit 981 (HIKE).

References

- Cascini, G., Fantoni, G., Montagna, F., "Reflections on the FBS model: proposal for an extension to needs and requirements modeling", *Proceedings of the 11th International Design Conference DESIGN 2010*, Marjanovic D., Storga M., Pavkovic N., Bojetic N. (ed.), 2010, pp. 651-660.
- Dorf, R. C., Bishop, R. H., "Modern control systems", Pearson, New Jersey, 2011.
- Frank, U., "Spezifikationstechnik zur Beschreibung der Prinziplösung selbstoptimierender Systeme", Westfalia-Druck GmbH Paderborn (Germany), 2006.
- Gausemeier, J., Tschirner, C., Dumitrescu, R., Gaukster, T., "Integrative Konzipierung von Produkt und Produktionssystem als Basis für eine erfolgreiche Produktentstehung". *Entwerfen, Entwickeln Erleben - Methoden und Werkzeuge in Produktentwicklung und Design*, Stelzer, R., Grote, K.-H., Brökel, K., Rieg, F., Feldhusen, J. (ed.), 2012, pp. 395-413.
- Gero, J. S., Kannengiesser, U., "The situated function – behaviour – structure framework", *Design studies*, Vol. 25 Issue 4, 2004, pp. 373-391.
- Hagelshuer, B., "Schulterschluss von Mechanik und Elektrik", *Konstruktion*, Vol. 4, 2013, pp. 58-59.

- Kaiser, L., "Rahmenwerk zur Modellierung einer plausiblen Systemstruktur mechatronischer Systeme", *Phd Thesis, University of Paderborn (Germany)*, 2013.
- Krehmer, H., "Vorgehensmodell zum Iterations- und Produktreifegradmanagement in der eigenschaftsbasierten Produktentwicklung", *VDI Verlag Düsseldorf (Germany)*, 2012.
- Luft, T., Kamin, S., Miebling, J., Lang, F. R., Wartzack, S., "Die eigenschaftsbasierte Produktentwicklung unter Berücksichtigung der differenziellen Anforderungen älterer Nutzer", *Proceedings of the 24th Symposium on Design for X*, Meerkamm, H. (ed.), *TuTech Verlag*, 2013, pp. 197-208.
- Luft, T., Wartzack, S., "Die matrixbasierte Produktbeschreibung als Bestandteil des Vorgehensmodells in der eigenschaftsbasierten Produktentwicklung", *Proceedings of the Stuttgarter Symposium für Produktentwicklung 2013 (SSP)*, Spath, D., Bertische, B., Binz, H. (ed.), *Fraunhofer Verlag Stuttgart (Germany)*, 2013.
- Paetzold, K., Schweiger, W., "Entwurf mechatronischer Systeme", *interim report of the CEFÉ working group "Modellbildung und Simulation im Produktentstehungsprozeß"*, Erlange, Nürnberg, 2002.
- Reinthalder, A., "Basics of application of the CPM-Modell following Weber", *student research project*, 2013.
- Rieke, J., Dorociak, R., Sudmann, O., Gausemeier, J., Schäfer, W., "Management of cross-domain model consistency for behavioral models of mechatronic systems", *Proceedings of the 12th International Design Conference DESIGN 2012*, Marjanovic D., Storga M., Pavkovic N., Bojcetic N. (ed.), 2012, pp. 1781-1790.
- Sendler, U., "Ganzheitliche Strategie: Systems Lifecycle Management (SysLM)", *Proceedings of Tag des Systems Engineering (TdSE) 2012*, Maurer, M., Schulze, S.-O. (ed.), *Carl Hanser München (Germany)*, 2012, pp. 43-52.
- Stiegler, A., Maletz, M., Mrotzek, M., Weck, T., "Generierung eines multiperspektiven Systemmodells in der automobilen Antriebsstrangentwicklung – Herausforderungen und Erfahrungen", *Proceedings of Tag des Systems Engineering (TdSE) 2012*, Maurer, M., Schulze, S.-O. (ed.), *Carl Hanser München (Germany)*, 2012, pp. 143-152.
- Suh, N. P., "Axiomatic Design Theory für Systems", *Research in Engineering Design, Vol 10*, 1998, pp. 189-209.
- Vajna, S., Weber, C., Bley, H., Zeman, H., "CAx für Ingenieure – Eine praxisbezogene Einführung", *Springer Berlin, Heidelberg (Germany)*, 2009.
- VDI, "Design methodology for mechatronic systems", (*Verein deutscher Ingenieure*), *VDI 2206*, Beuth GmbH Berlin (Germany), 2004.
- Wäldele, M., "Erarbeitung einer Theorie der Eigenschaften technischer Produkte – Ein Beitrag für die konventionelle und algorithmenbasierte Produktentwicklung", *VDI Verlag Düsseldorf (Germany)*, 2012.
- Weber, C., "CPM/PDD – An extended theoretical approach to modelling products and product development processes", *Proceedings of the 2nd German-Israeli Symposium on Advances in Methods and Systems for Development of Products and Processes*, Bley, H.; Jansen, H.; Krause, F.-L.; Shpitalni, M (ed.), *Fraunhofer-IRB-Verlag Stuttgart (Germany)*, 2005, pp. 159-179.
- Weber, C., "Produkte und Produktentwicklungsprozesse abbilden mit Hilfe von Merkmalen und Eigenschaften – eine kritische Zwischenbilanz", *Proceedings of the 23rd Symposium on Design for X*, Krause, D., Paetzold, K., Wartzack, S. (ed.), *TuTech Verlag, Bamberg (Germany)*, 2012, pp. 25-62.
- Weber, C., Wener, H., "Klassifikation von CAX-Werkzeugen für die Produktentwicklung auf der Basis eines neuartigen Produkt- und Prozessmodells", *Proceedings of the 11th Symposium on Design for X*, Meerkamm, H. (ed.), *Schnaittach/Erlangen (Germany)*, 2000, pp. 126-143.
- Weickgenannt, M., "Konzepte zur modellbasierten Regelung adaptiver Schalenträgerwerke", *Shaker Aachen (Germany)*, 2013.
- Zingel, C., Albers, A., Matthiesen, S., Maletz, M., "Experiences and Advancements from One Year of explorative application of an integrated model-based-development technique using C&C²-A in SysML", *International Journal of computer science (IJCS)*, Vol. 39, 2012, pp. 165-181.

Dipl.-Ing. Alexander Crostack, Academic Assistant
 Institute for Engineering Design and Industrial Design (IKTD), University of Stuttgart
 Pfaffenwaldring 9, 70569 Stuttgart, Germany
 Telephone: +49 711 685 66041
 Email: alexander.crostack@iktd.uni-stuttgart.de
 URL: <http://www.iktd.uni-stuttgart.de>